

JERR-DAN[®]
RUN HARD™

An Oshkosh Corporation Company

70/85 ROTATOR

TURN A HUGE PROFIT.

All equipment ratings specified are based on structural capacity only and comply with SAE J2512 and J706 Recommended Practices and may be limited by the axle rating and Gross Vehicle Weight Rating of the truck chassis.

All measurements and ratings are nominal values.

All outside frame rails extending behind the cab of the chassis must be free of all air tanks, battery boxes, fuel tanks, etc.

The payload and towing capacity of any towing vehicle must meet the following: The actual payload on the towing vehicle must not exceed the posted rating and the towed vehicle load must not exceed the posted lift/towing ratings; the total weight of the towing vehicle (cab chassis, body, payload, driver, passenger(s), tools, fuel, etc.) and the towed vehicle load must not exceed the GVWR (Gross Vehicle Weight Rating) of the towing vehicle; the total weight of the towing vehicle and a towed vehicle load must be distributed so that each axle's GAWR (Gross Axle Weight Rating) is not exceeded; the total weight of the towing vehicle and towed vehicle (everything that moves with the towing vehicle) must not exceed the GCWR (Gross Combination Weight Rating) of the towing vehicle. Staying within these ratings is necessary to maintain the safety and performance of the towing vehicle.

Manufactured under one or more of the following patents: 5,575,606; 5,575,042; 5,697,741; 5,713,714; 5,722,810; 5,782,596; 5,839,775 and 6,315,515 with other Patents Pending.

Specifications, descriptions and illustrative material contained within this literature are as accurate as known at the time of publication, but are subject to change, without notice, as a result of continuous product improvements.

Illustrations may include optional equipment and accessories and may not include all standard equipment.

Always check with an authorized sales representative or call 800-926-9666 for current information.

Jerr-Dan and the Jerr-Dan logo are registered trademarks of Jerr-Dan Corporation, Greencastle, PA USA.

©Copyright Jerr-Dan Corporation, 1080 Hykes Road · Greencastle, PA 17225 · 800-926-9666 · 717-597-7111 · Fax: 717-593-6183 · www.jerr-dan.com

JD-0005-ROTATOR
11/08

JERR-DAN[®]
RUN HARD™

An Oshkosh Corporation Company



70/85 ROTATOR



HEAVY. FOR YOUR DUTY.

70/85 ROTATOR

Your profit. That's what really matters. With the Jerr-Dan® 70/85 Rotator, plan on elevating your profits as you recover from every angle. Jerr-Dan got it right the first time, utilizing a torsion box frame and outrigger system, creating the strongest platform in the industry. Recover at 360°. Turn your profits around 180°. Run hard with the 70/85 Rotator from Jerr-Dan.

Recommended Minimum Chassis Requirements:

GVWR:	Tandem Axle 86,000 lbs
Cab to Tandem/Cab to Drive Tandem (clear):	240"
Frame RBM (each rail):	4,200,000 in-lbs
Front GAWR:	20,000 lbs
Rear GAWR:	46,000 lbs
Lift Axle GAWR:	20,000 lbs
Maximum Unloaded Frame Height:	42"

FEATURES



1. Wilburt Tower Lighting
Also comes with tilt and pan feature to light up the whole scene and prevent shadows when working close to the rig.



2. Remote Control*
Paddle style proportional remote control provides the ultimate in feather control operation.



3. Quadra Flare Lights
Strategically positioned for added safety at the scene.



4. 3 Section Boom
Optional 3 section boom provides a 42' reach from the centerline of rotation.



5. Emergency Stop in Control Panel
Maintain complete control of the situation with an Emergency Stop positioned right in the control panel.



6. Dual Free Spool, Speed Controls and Gauges
Provides access to these functions from either passenger or driver side of the truck.



7. Storage Drawers
Provides additional storage with easy access.



8. Boom Angle Indicator*
Allows operator to position boom at proper degree.



9. Gunnebo Hooks and Boom Cable Tie Backs*
Gunnebo hooks provide the ultimate in rigging safety.



10. Boom Auxiliary Winch
Provides additional winches for catching and recovery that follow the direction of the boom.



11. Underlift Drag Winch
Solid. Powerful. Strong. This winch will pull even the heaviest of recoveries.



12. Boom Lights
For greater safety on site. Shown with optional Hella lights.

* Denotes standard features. All others shown are optional.

Top Five Reasons To Make The 70/85 Rotator Yours

1. A tip load rating of 18,400 lbs – greater than the leading competitor.
2. Extreme stability with the widest double scissors-style outrigger spread in the industry – 112" by 264".
3. Unique scissors-style stabilizer design that keeps loads closer to the ground and body when lifting over the outrigger's extended beams.
4. Outriggers with integral spades that are designed to provide 26" penetration for utmost stability on many areas with uneven terrain.
5. A working radius of nearly 42' – a full 8' more than the leading competitor.

SPECIFICATIONS

	DISTANCE	RATING
A. Centerline of Rear Tandem to Rear of Tailboard	66"	
B. Reach with Forks, retracted (rear of tailboard to centerline of forks)		
Standard Underlift - HDUL530	72"	53,000 lbs
Optional Coach Underlift - HDUL565	87"	56,500 lbs
C. Reach with Forks, extended (rear of tailboard to centerline of forks)		
Standard Underlift - HDUL530	142"	17,000 lbs
Optional Coach Underlift - HDUL565	181"	17,600 lbs
D. Maximum Horizontal Towing Height with Forks		
Standard Underlift - HDUL530	38"	
Optional Coach Underlift - HDUL565	38"	
E. Boom Reach Off Rear of Tailboard (boom @ 0°)		
Standard - 2 Section Boom	162"	
Optional - 3 Section Boom	299"	
F. Boom Working Height to Hook (boom @ 51°)		
Standard - 2 Section Boom	374"	
Optional - 3 Section Boom	481"	
G. Boom Maximum Height (boom @ 51°)		
Standard - 2 Section Boom	408"	
Optional - 3 Section Boom	515"	
H. Boom Working Radius, retracted (boom @ 51°)		
Standard - 2 Section Boom	125"	
Optional - 3 Section Boom	135"	
I. Boom Working Radius, extended (boom @ 51°)		
Standard - 2 Section Boom	226"	
Optional - 3 Section Boom	313"	
J. Boom Working Radius, retracted (boom @ 0°)		
Standard - 2 Section Boom	211"	
Optional - 3 Section Boom	221"	
K. Boom Working Radius, extended (boom @ 0°)		
Standard - 2 Section Boom	365"	
Optional - 3 Section Boom	502"	
L. Outrigger Spread, retracted	160"	
M. Outrigger Spread, half extended	250"	
N. Outrigger Spread, extended	264"	
O. Maximum Outrigger Ground Penetration	26"	
P. Maximum Outrigger Ground Clearance	12"	

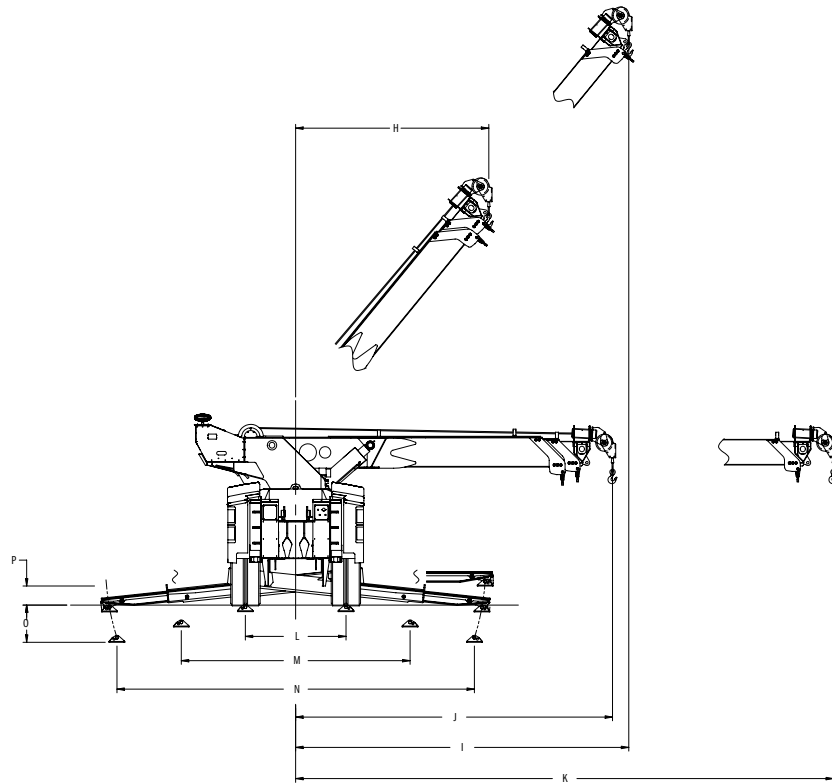

BOOM LIFT RATINGS (SAE J2512)

	RATING
Maximum Structural Limit (boom fully elevated and retracted over the rear)	170,000 lbs
Maximum Rated Loads (boom fully elevated and retracted over the rear)	140,000 lbs

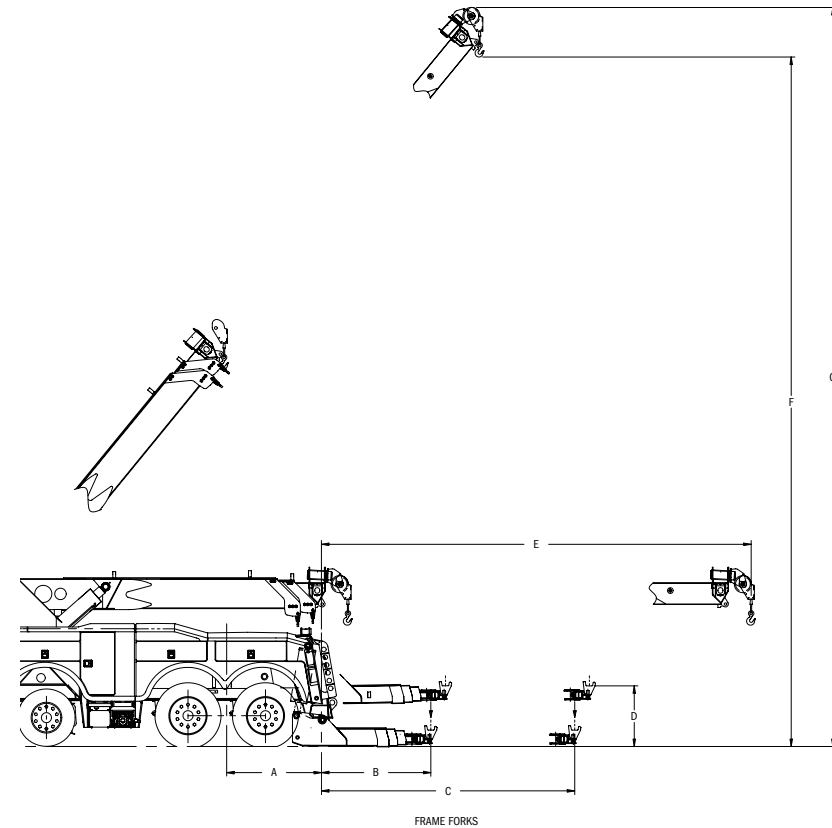
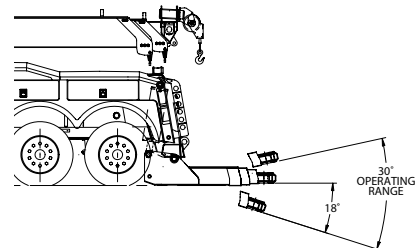

STANDARD EQUIPMENT

	FEATURES	70/85 ROTATOR	
Wrecker Boom	2 Section Wrecker Boom Lift Rating @ 30°	Retracted 120,000 lbs Extended 44,000 lbs	
	Boom Reach Off Rear of Tailboard (boom @ 0°)	162"	
	Boom Rotation	360°	
	Boom Working Angle	Minimum 0° Maximum 51°	
	Boom Working Height to Hook (boom @ 51°)	374"	
	Boom Maximum Height (boom @ 51°)	408"	
	Boom Working Radius (boom @ 51°)	Retracted 125" Extended 226"	
	Boom Working Radius (boom @ 0°)	Retracted 211" Extended 365"	
	High Performance Polymer Slide Pads	X	
	Mechanical Boom Angle Indicators	X	
	Dual 360° Swivel Boom Sheave Head	X	
	4 Boom D-Rings	Base 2 Fly 2	
	Wire Rope / Cable Boom Paint Protectors	X	
	Wire Rope / Cable Tie Backs	X	
	Underlift	Underlift Type - HDUL530	3 Section - Independent
Power Tilt and Fold		Positive 12° Negative 18°	
Lift / Tow Rating with Forks		Retracted 53,000 lbs / 80,000 lbs Extended 17,000 lbs / 80,000 lbs	
Reach with Forks (rear of tailboard to centerline of forks)		Retracted 72" Extended 142"	
Maximum Horizontal Towing Height with Forks		38"	
Hydraulic Extension		70"	
Low-Profile Height Crossbar		X	
Cast Frame Fork Receivers		1 Set	
Cast Frame Forks		4 Sets	
Chain Hook Adapters		1 Set	
Spring Lift Attachments		1 Set	
Built-In Safety Chains with Storage Pockets		X	
Alloy Tie-Down Chains		X	
Wrecker Boom Winch		Dual 50,000 lb 2 Speed Planetary Winches	X
		3/4" Dia x 250' Long (6 x 37 IWRC RRL EIPS) Galvanized Winch Cables	X
	Air Controlled Winch Cable Tensioners	X	
	Passenger Side Remote Air Controlled Winch Free Spool Releases	X	
	Lighting	FMVSS 108 Light Group Utilizing Weather Resistant Harnesses and Connectors	X
		Back-Up Lights (pair)	X
		Amber Marker Lights in Winch Mounting Structure (2 per side)	X
		Tool Compartment Lighting	X
Control Station Lighting		X	
Winch Work Lights (pair)		X	
Lower Hook-Up Lights (pair)		X	
Outrigger Work Lights (4 pair)	X		
Turntable Pre-Wired for Lightbar and Work Lights	X		
Outriggers	Outrigger Type	Dual Front & Rear 3 Section	
	Front and Rear Scissors-Style Low-Profile Outriggers with Manual Lock Pins	X	
	Integral Folding Spades	X	
	D-Rings for Side Pulling	X	
	Outrigger Pads / Spades, 11" x 11" (set of 4)	X	
	Maximum Outrigger Ground Clearance	12"	
	Maximum Outrigger Ground Penetration	26"	
	Outrigger Spacing	Retracted 112" x 160" Mid 112" x 250" Extended 112" x 264"	
Rear Spades	Hydraulically Controlled Rear Pads with Flip-Down Claw / Spade and Integral Recovery Anchor	X	
Hydraulic System	Hydraulic Valve with Fully Proportional Manual Control	X	
	System Pressure	3,500 psi	
	Hydraulic Reservoir with Sight Gauge, Fluid Cut-Offs, Magnetic Clean-Out Provisions and 3 Replaceable 125 Micron Suction Strainers	X	
	Three 10 Micron In-Line Replaceable Return Filters with Service Indicator Gauges	X	
	Hydraulic Pressure Gauges - 4 on passenger side and 1 on driver side control station	X	
	Holding Valves on All Cylinders	X	
	Chrome Plated Cylinder Rods	X	
	System Overload Protection	X	
Controls	Driver and Passenger Side Fully Proportional Manual Hydraulic Controls with Wireless Proportional Remote Control for Wrecker Boom, Slew and Winch Functions and Non-Proportional Remote Control for Underlift, Drag Winch and Spade Functions - 22 Function	X	
	Driver and Passenger Side Fully Proportional Manual Hydraulic Outrigger Controls	X	
Paint	Prime Finish	X	
PTO	Air Shift PTO with Engagement Indicator Light	X	
	Direct Mount 3 Stage Gear Pump	X	

STANDARD EQUIPMENT

FEATURES	70/85 ROTATOR	
Modular Composite Body	Main Body Compartments (per side)	
	240" CT Main Body with Tri-Axle Panel – 246" CT	3 Horizontal – 4 Vertical
	264" CT Main Body with Tri-Axle Panel – 270" CT	3 Horizontal – 5 Vertical
	Removable Mid-Section Modular Body	X
	Aluminum Sub-Structure with Composite Panels	X
	Independently Rubber Shock Mounted Body	X
	Fender Flares	X
	Stainless Steel Paddle Latches	X
	Gas Spring Door Assist	X
	Built-In Tool Storage and Chain Racks	X
	Centerline of Rear Tandem to Rear of Tailboard	66"
Storage	24" Crossover Tool Compartment	X
	24" Under Frame Pullout Drawer – driver and passenger side	X
	16" Under Frame Tunnel Tool Compartment	X
Miscellaneous	Jerr-Dan® Mud Flaps	X
	Back-Up Alarm	X
	Air Actuated Slew Lock – over-the-rear and over-the-front	X
	Air Supply Disconnect at Rear of Body	X
	9 Function Switch Panel	X
	Turntable Mounted License Plate Holder	X
	Rear Recovery Anchors	8 Each Side
	Recessed 7-Way Electrical Connector at Rear of Body	X
	Recessed Glad Hand Connections at Rear of Body	X
	High Strength Steel Torque Box Style Carrier Frame (44,000,000 in-lbs RBM)	X

OPTIONAL EQUIPMENT

FEATURES	70/85 ROTATOR		
Wrecker Boom	3 Section Wrecker Boom Lift Rating @ 30°	Retracted 120,000 lbs Mid 44,000 lbs Extended 26,000 lbs	
	Boom Reach Off Rear of Tailboard (boom @ 0°)	299"	
	Boom Working Height to Hook (boom @ 51°)	481"	
	Boom Maximum Height (boom @ 51°)	515"	
	Boom Working Radius (boom @ 51°)	Retracted 135"	
		Extended 313"	
	Boom Working Radius (boom @ 0°)	Retracted 221"	
		Extended 502"	
	High Performance Polymer Slide Pads	X	
	Mechanical Boom Angle Indicators	X	
	Dual 360° Swivel Boom Sheave Head	X	
	6 Boom D-Rings	Base 2	
		Mid 2	
		Fly 2	
	Wire Rope / Cable Boom Paint Protectors	X	
	Wire Rope / Cable Tie Backs	X	
	Underlift	Coach Underlift – HDUL565	
		Underlift Type	3 Section – Independent
		Lift / Tow Rating with Forks	Retracted 56,500 lbs / 80,000 lbs
			Extended 17,600 lbs / 80,000 lbs
		Reach with Forks (rear of tailboard to centerline of forks)	Retracted 87"
Extended 181"			
Maximum Horizontal Towing Height with Forks		38"	
Hydraulic Extension		94"	
Heavy-Duty Tire Lift – HDTL1			
Lift / Tow Rating with Heavy-Duty Tire Lift		Retracted 14,000 lbs / 80,000 lbs	
		Extended 14,000 lbs / 80,000 lbs	
Reach with Heavy-Duty Tire Lift (rear of tailboard to centerline of tire lift) (with standard underlift / with coach underlift)		Retracted 67" / 82"	
		Extended 137" / 176"	
Maximum Horizontal Towing Height with Heavy-Duty Tire Lift (with standard underlift / with coach underlift)		29" / 29"	
Hydraulic Extension (with standard underlift / with coach underlift)		70" / 94"	
Tie-Down Straps and Ratchets		1 Pair	
Super Heavy-Duty Tire Lift – SHDTL1			
Lift / Tow Rating with Super Heavy-Duty Tire Lift		Retracted 25,000 lbs / 80,000 lbs	
		Extended 25,000 lbs / 80,000 lbs	
Reach with Super Heavy-Duty Tire Lift (rear of tailboard to centerline of tire lift) (with standard underlift / with coach underlift)		Retracted 67" / 82"	
		Extended 137" / 176"	
Maximum Horizontal Towing Height with Super Heavy-Duty Tire Lift (with standard underlift / with coach underlift)	29" / 29"		
Hydraulic Extension (with standard underlift / with coach underlift)	70" / 94"		
Tie-Down Straps and Ratchets	1 Pair		
Towing	Fifth Wheel Attachment – 15,000 lb lift / 25,000 lb tow rating	X	
	Pintle Hook with 2" or 50 mm Dia Trailer Ball – 3,000 lb lift / 16,000 lb (hook), 7,000 lb (ball) tow rating <i>Requires Fifth Wheel Attachment Option</i>	X	
	1-7/8", 2", 2-5/16" or 50 mm Dia Pintle Hook Trailer Ball – 3,000 lb lift / 2,000 lb; 7,000 lb; 10,000 lb; 6,614 lb respective tow rating	X	
	Small Tie-Down Straps for Heavy-Duty Tire Lift	1 Pair	

OPTIONAL EQUIPMENT

FEATURES	70/85 ROTATOR		
Winch	Wrecker Boom Winch		
	Dual 60,000 lb Single Speed Planetary Winches with 7/8" Dia x 245' Long (6 x 36 IWRC RRL EEIPS) Cables with Swivel Hooks ILO Standard Dual Winches	X	
	Dual 60,000 lb 2 Speed Planetary Winches with 7/8" Dia x 245' Long (6 x 36 IWRC RRL EEIPS) Cables with Swivel Hooks ILO Standard Dual Winches	X	
	Dual 60,000 lb Single Speed Planetary Winches with 1" Dia x 220' Long (6 x 36 IWRC RRL EEIPS) Cables with Swivel Hooks ILO Standard Dual Winches	X	
	Dual 60,000 lb 2 Speed Planetary Winches with 1" Dia x 220' Long (6 x 36 IWRC RRL EEIPS) Cables with Swivel Hooks ILO Standard Dual Winches	X	
	Wrecker Boom Wing Winch		
	Dual 20,000 lb Single Speed Boom Wing Mounted Planetary Winches with 9/16" Dia x 150' Long (6 X 37 IWRC RRL EIPS) Galvanized Cables with Swivel Hooks	X	
	Underlift Drag Winch		
	35,000 lb Single Speed Planetary Underlift Drag Winch with 5/8" Dia x 250' Long (6 x 37 IWRC RRL EIPS) Galvanized Cable with Swivel Hook	X	
	35,000 lb 2 Speed Planetary Underlift Drag Winch with 5/8" Dia x 250' Long (6 x 37 IWRC RRL EIPS) Galvanized Cable with Swivel Hook	X	
	Winch Cable	Swivel Hook for Wrecker Boom Winch Cables ILO Standard Winch Cable	X
Swivel Hook for Underlift Drag Winch Cable ILO Standard Winch Cable		X	
Outriggers	Large Outrigger Pads / Spades ILO Standard, 16" x 20"	Set of 4	
	Outrigger Support Pads – wood or rubber	Set of 4	
Lighting	LED Tail Lights with Steel or Stainless Steel Housing	X	
	72" or 91" Amber LED Lightbar	X	
	Wing Mounted Emergency Lightbar – choice of 4-head 22" Amber LED Lightbars (pair), 2-head 22" Amber Strobe Lightbars (pair), or 22" Amber Halogen Rotator Lightbar (pair)	X	
	Upper Hook-Up Lights	1 Pair	
	Upper Work Lights	1 Pair	
	Underlift Hook-Up Light	X	
	Wrecker Boom Work Lights	Set of 3	
	In Body Amber / Red Marker Light Kit – Incandescent or LED	X	
	Under Body Amber Marker Light Kit – Incandescent or LED	X	
	In Body and Under Body Amber / Red Marker Light Kit – Incandescent or LED	X	
	Extend-A-Light Kit (2 lights)	X	
Quadra Flare Light Kit – 5 pairs on side, 2 pairs at rear	X		
Controls	Wireless Proportional Remote Control for Wrecker Boom, Slew and Winch Functions and Non-Proportional Remote Control for Underlift, Drag Winch and Spade Functions ILO Standard Wireless Remote Control – 26 Function	X	
Storage	24" Tunnel Tool Compartment	X	
	24" 3/4 Height Tunnel Tool Compartment	X	
	24" Stand Alone Tool Compartment	X	
	24" 3/4 Height Stand Alone Tool Compartment	X	
	49" Double-Door Crossover Tool Compartment	X	
	49" Double-Door 3/4 Height Stand Alone Tool Compartment	X	
	49" Double-Door 3/4 Height Special Stand Alone Tool Compartment	X	
	49" Double-Door Crossover Tool Compartment with External Pullout Drawers	X	
	49" Double-Door Crossover Tool Compartment with Internal Pullout Drawer(s) for Driver Side, Passenger Side or Both Sides	X	
	24" Under Tunnel Tool Compartment Drawer	X	
	49" Under Tunnel Tool Compartment Drawer	X	
	Tray for 49" Tunnel Tool Compartment	X	
	Paint	Custom Paint Colors Available	X
	PTO	Clutch Shift PTO	X
Miscellaneous	ABS Brake Wire / Cables	X	
	Air Hose Reel with 3/8" Dia x 50' Long or 1/2" Dia x 100' Long Hose	X	
	Chain Binder Rack	X	
	Chain Binders for 1/2" Chain	X	
	Custom Stainless Steel Tailplates	X	
	Electronic Inclinometer Kit	X	
	Frame Stretch / Frame Modification	X	
	Heavy-Duty Tie Back Plates	X	
	Hydraulic Generator Kit	X	
	Hydraulic Oil Reservoir Heater	X	
	Inversion Valve Kit	X	
	Locate Batteries in Driver or Passenger Side 24" or 49" Tunnel Tool Compartment	X	
	On-Board Truck Scales	X	
	R12 Relay Valve	X	
	Snatch Block – 12 Ton, 8" Dia Sheave	X	
	Snatch Block – 12 Ton, 10" Dia Sheave	X	
	Snatch Block – 22 Ton, 10" Dia Sheave	X	
	Stainless Steel Dress-Up Kit for 24" or 49" Under Tool Compartment Drawer	X	
	Steerable Lift Axle – 20,000 lb rating	X	
	Tire Lift Storage Brackets for 24" or 49" Tunnel Tool Compartment	X	
	Underlift Stabilizer Rings	1 Pair	
Underlift Toolholder Brackets	X		
Video Camera Kit	X		

All dimensions are based on a 42" truck frame height and are rounded to the nearest inch. Values subject to change without notice.